

INSTRUCTION MANUAL

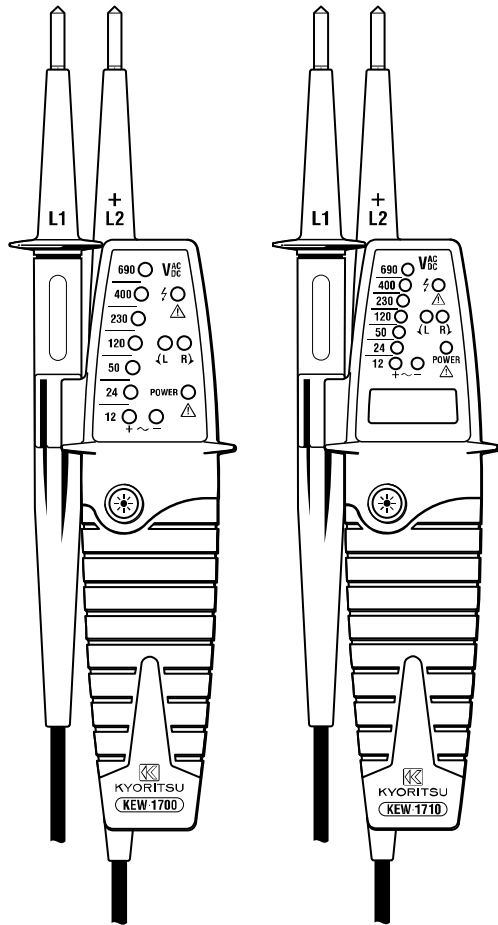

VOLTAGE TESTER

KEW 1700 / 1710



KYORITSU ELECTRICAL INSTRUMENTS WORKS, LTD.

1. Features

- Designed to meet international safety standards. IEC61243-3 / IEC61010-1 Measurement Category (CAT.) IV 600V
- Self-Diagnostic test
- AC and DC voltage test up to 690V with LEDs and LCD (only KEW1710).
- Polarity indication
- Single-pole phase test
- Phase rotation test
- Continuity test
- Auto-power ON / OFF
- Pen light for illuminating measurement points
- Two way clip for adjustable spacing of probes
- Selectable probe Tips 1.6/4mm
- Probe cover protects user and Tips
- IP65 (IEC60529)
- Compact design (Light weight and portable)

2. Safety Warnings

This instrument has been designed, manufactured and tested according to IEC 61010/61243: Safety requirements for Electronic Measuring apparatus, and is supplied having passed rigorous quality procedures.

This instruction manual contains warnings and safety rules which have to be observed by the user to ensure safe operation of the instrument and to maintain it in safe condition. Therefore, read through these operating instructions before using the instrument.

⚠WARNING is reserved for conditions and actions that are likely to cause serious or fatal injury. **⚠CAUTION** is reserved for conditions and actions that can cause injury or instrument damage.

It is essential that the above instructions are adhered to. Failure to follow the above instructions may cause injury, instrument damage and/or damage to equipment under test.

Symbols used on the instrument

	User must refer to the explanations in the instruction manual.
	Instrument with double or reinforced insulation, Class II insulation
	Insulated personnel body protective equipment up to 690V.
CAT.IV	The source of the low-voltage installation: Eg. Electricity meters and primary overcurrent protection devices. Estimated transient overvoltage 8kV.
CE	Comply with EMC and Low Voltage Directive

⚠WARNING

- Never make measurement on a circuit in which the electrical potential exceeds 690V.
- Do not attempt to make measurement in the presence of flammable gasses, as the use of the instrument may cause sparking, which could lead to an explosion.
- Never attempt to use the instrument if it's surface or your hands are wet. (Do not use in rainfall.)
- Keep your hands and fingers behind the barriers during measurements.
- Never unlock and open the Battery case during measurements.
- Verify proper operation on a known source before use or taking action as a result of the indication after use.
- Never attempt to make any measurement if any abnormal conditions, such as a broken case or exposed metal parts are present on the Instrument or test probes.
- Do not make any modification to the instrument.
- Extreme caution when *Live circuit LED* flashes or lights on.
- Correct indication of LEDs is only guaranteed within a temperature range of -10°C up to 55°C (<85% RH).

3. Instrument layout

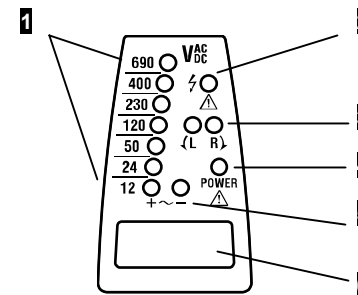

- 1 12/24/50/120/230/400/690V LEDs for voltage indication
- 2 Live circuit LED for Single-pole phase and Double-pole test
- 3 L/R LEDs for phase rotation test
- 4 Power LED
- 5 Polarity indication LEDs for voltage
- 6 LCD (only KEW1710)

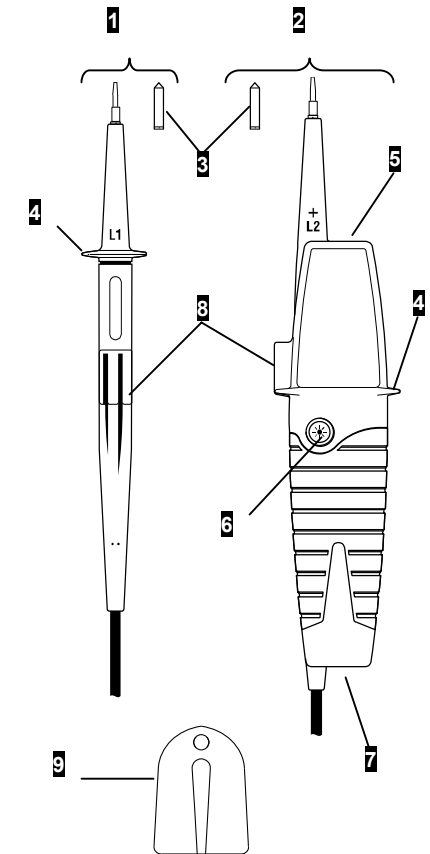

- 1 L1 probe -
 - 2 L2 probe + (Instrument probe)
 - 3 4mm tips
 - 4 Barrier
 - 5 Pen light
 - 6 Pen light switch
 - 7 Battery case
- 8 Probe clip (two way)
9 Probe protection cover

4. Preparation for measurement

4.1 Auto-power-on / Self-diagnostic test

•Auto-power-on

- ▶ Short-circuiting the probes as follows powers on the instrument automatically and goes into a Self-diagnostic test.

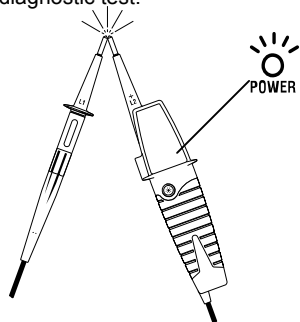

Instrument may power on;
* when replacing Tips, or
* due to the influence of static charge.

•Self-diagnostic test

⚠WARNING
Do not use the instrument when abnormality is found at Self-diagnostic test.

- ▶ Battery voltage is normal when *Power LED* is lighting up.
When the battery voltage is below $2.4 \pm 0.1V$, *Power LED* flashes or goes off.
Replace batteries according to Clause 7.
- ▶ LEDs other than the *Power LED* should be flashing and buzzer should sound continuously.

•Auto-power off

- ▶ Instrument is automatically powered off after 15 sec when nothing is contacted with the probes. (*Power LED* goes off.)

Auto-power off may not operate;
* when replacing Tips, or
* when a significant electric magnetic field exists in the vicinity.

4.2 Trouble-shooting

If the following problems occur, unlock the Battery Case according to clause 7 in this manual, and then lock it again 5 seconds later. Then perform the self-diagnostic test (clause 4.1).

- * Self-diagnostic test cannot be performed before/after use of the instrument.
- * Auto-power off doesn't operate.

5. Handy construction

Diameter of Tip and pitch between Tips are changeable by user.

⚠WARNING
Remove the probes from the measurement point when replacing Tips or changing pitches.

5.1 Tip Replacement

- ▶ Following shows how to install 4mm Tips on L1 probe – and L2 probe +.

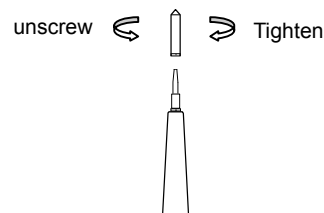

- ▶ Firmly tighten up the 4mm Tips.

5.2 Pitch between two probes

- ▶ Pitch between 2 Tips can be 16.7mm or 19.0mm when rotating L1 probe – by 180 degrees and sliding in the hooks on L2 probe +.

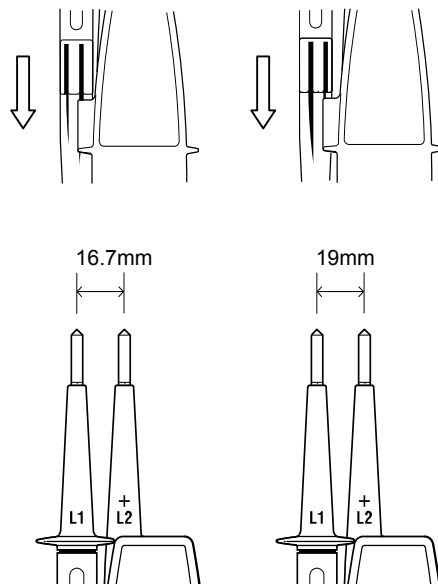

6. Measurement

⚠WARNING

- Carefully check Clause 2 as well.
- Self-diagnostic test should be done prior to measurements and confirm LED and Buzzer works properly.
- Verify proper operation on a known source before and after use.
- Keep your hand and fingers behind the barriers on the probes during measurements.
- Due to the high internal resistance (approx. $300k\Omega$), the capacitive and inductive voltages may be indicated.

6.1 Voltage test (Double-pole test)

- ▶ Connect both probes to the object under test.

- ▶ The voltage is indicated by LEDs and LCD (only KEW1710).

Buzzer sounds when a threshold voltage of 50V LED is exceeded.

Live circuit LED lights up :
> 0.3V AC
> 7V DC

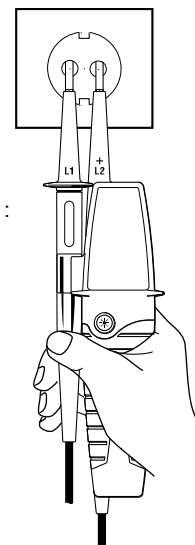

- ▶ Voltage polarity is indicated in following manner.



NOTE

- This instrument can make measurements between L-PE without tripping RCDs.
- When the L2 probe + is the positive (negative) potential, the *Polarity indication LED* indicates "+DC" ("-DC").
- L/R LED may light up.

6.2 Double-pole test without batteries

⚠WARNING

Verification of live-circuit shouldn't be dependent on Double-pole test without batteries only, but also on the test WITH BATTERIES. (See Clause 6.1).

Only *Live circuit LED* flashes when Double-pole test is carried out without batteries.

LED flashes: AC/DCV > approx. 40V
Flashing Duty: < 3s (40...100V)
< 0.3s (100...690V)

6.3 Single-pole phase test

⚠WARNING

•Carefully handle L1 probe – when it is not in use.
•Function of this test may not be fully achieved if the insulation condition of user or of the equipment under test isn't enough.
Verification of live-circuit shouldn't be dependent on this Single-pole phase test only, but also on the Double-pole test. (See Clause 6.1.)

- ▶ Grasp the instrument firmly and connect the L2 probe + to the object under test.
- ▶ *Live circuit LED* lights up and buzzer sounds when a voltage of approx. 100V AC or more exists in the object under test. ($Pol \geq 100VAC$)

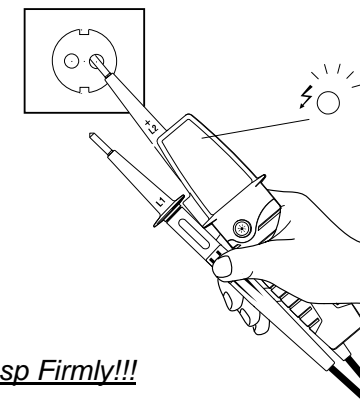

Grasp Firmly!!!

6.4 Phase rotation test

L LED and R LED for Phase rotation test may operate on various wiring systems, but effective testing result can be obtained only on Three-phase 4-wire system.

- ▶ Grasp the instrument firmly and connect both probes to the object under test.
- ▶ Phase-to-phase voltage is indicated by each Voltage LED.
- ▶ R LED lights up for Right rotary field.

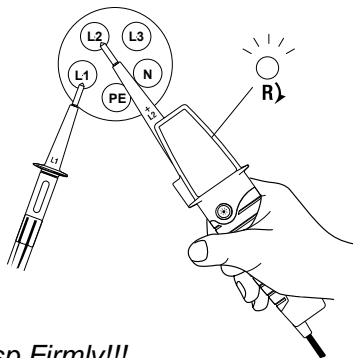

Grasp Firmly!!!

- ▶ L LED lights up for Left rotary field.

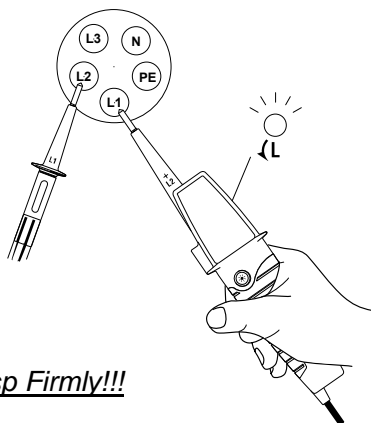

Grasp Firmly!!!

The principle of measurement

The instrument detects the phase rising order regarding the user as EARTH.

NOTE

Function of this test may not be fully achieved if the insulation condition of user or of the equipment under test is not enough.

6.5 Continuity test

⚠WARNING

Make sure the object under test isn't live.

Instrument operates as follows when measuring Continuity.

- ▶ All LEDs other than *Power LED* should be flashing, and buzzer should sound continuously.

NOTE

In continuity mode the instrument works in the same way as the self-diagnostic test.

6.6 Pen light function

(Illuminating the Measurement Point)
Equipped Pen light illuminates the measurement point in dimly lit area.

- ▶ Pressing the Pen light switch turns on the light.

NOTE

- The light is available while the instrument is powered off.
- Using the Pen light shortens the battery life.

7. Battery Replacement

⚠WARNING

Remove the probes from any testing point, when opening the Battery case.

Batteries are dead when *Power LED* flashes or goes off at Self-diagnostic test defined in point 4.1. Follow the procedure below and replace batteries with new ones (type IEC LR03 1.5V).

- ▶ Unlock the Battery case with a coin-shaped object.

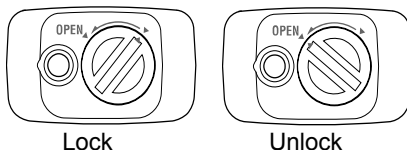

- ▶ Pull out the Battery case and replace the batteries. Insert new batteries according to the engraving on the Battery case.

- ▶ Insert the Battery case into the instrument and firmly lock the case again.

⚠WARNING

Confirm that the Battery case is properly locked prior to measurements.

8. Specification

Voltage test	
Voltage range	12...690V AC/DC
LED (KEW1700 / 1710)	
Nominal voltage	12/24/50/120/230/400/690V AC(45...400Hz), DC(±)
Tolerance (Threshold voltage)	Light on at more than : 7±3V (12V LED) : 18±3V (24V LED) : 37.5±4V (50V LED) : 75%±5% of nominal voltage (120/230/400/690V LED)
Response time	< 0.5s at 100% of each nominal voltage
LCD (only KEW1710)	
Range / Resolution (Auto-range)	300V (7.0...299.9) / 0.1V 690V (270...759) / 1V
Accuracy (23±5°C)	±1.5V (7...100V) ±1%±5dgt (100...690V) AC(45...400Hz), DC(±)
Overrange indication	"OL"
Response time	< 2s at 90% of each voltage
Peak current	Is<3.5mA (at 690V)
Measurement Duty	30s ON (operation time) 240s OFF (recovery time)
Internal battery consumption	Approx. 33mA (battery 3V, measuring 690V AC)
Battery life	Approx. 2500 operations (30s ON / 240s OFF duty)
Single-pole phase test	
Voltage range	100...690V AC (45...100Hz) 180...690V AC (100...400Hz)
Phase rotation test	
System	Three-phase 4-wire system 200...690V phase-to-phase (100...400V earth-to-phase) AC 50/60Hz
Phase range	120±5 degree
Continuity test	
Detection range	0...400kΩ + 50%
Test current	Approx. 1.5μA (battery 3V, 0Ω)
Internal battery consumption	Approx. 30mA (battery 3V, 0Ω)
Reference condition	
Battery	3V (IEC LR03 1.5V × 2)
Temperature	-10...55°C operation -20...60°C storage No condensation
Humidity	Max 85% RH
Used location	Altitude up to 2000m
Safety	
Standard	IEC61010-1, CAT.III /IV 600V
Category	IEC61243-3, CAT.II 690V
Pollution degree	2
IP code	IP65 (IEC60529)
Size	
Dimensions	241.5 x 68.5 x 28.5mm
Weight	230g (including batteries)

9. Cleaning and storage

⚠CAUTION

- Use a lightly damp cloth with neutral detergent for cleaning the instrument. Do not use abrasives or solvents.
- Do not expose the instrument to the direct sun, high temperature and humidity or dewfall.
- Put the Probe protection cover on the Tips while not in use. Otherwise it may cause an injury.
- Remove batteries when the instrument will not be in use for a long period.
- Do not install the Battery Case without batteries.

10. For Environment



This instrument is subject to WEEE Directive (2002/96/EC). Please contact your dealer near you at disposal.

DISTRIBUTOR

Kyoritsu reserves the rights to change specifications or designs described in this manual without notice and without obligations.



KYORITSU ELECTRICAL INSTRUMENTS WORKS, LTD.

No.5-20, Nakane 2—chome, Meguro-ku, Tokyo, 152-0031 Japan
Phone : 81—3—3723—0131
Fax : 81—3—3723—0152
URL : <http://www.kew-ltd.co.jp>
E-mail : info@kew-ltd.co.jp
Factories : Uwajima & Ehime