

Instruction manual

KEW 5515

Hand-held Infrared Thermometer

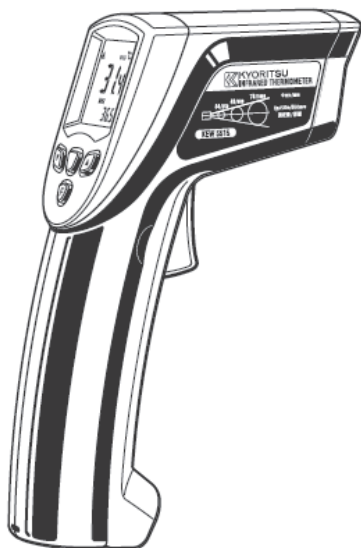

**KYORITSU ELECTRICAL
INSTRUMENTS WORKS, LTD.**

Contents

1. Safety precautions	1
1-1. DANGER	1
1-2. WARNING	1
1-3. CAUTION	1
1-4. Environmental precautions	2
1-5. Maintenance	2
1-6. Relation of distance and measuring diameter	2
2. Features	3
3. Specifications	3
4. Name of each part	5
4-1. Body	5
4-2. Display part (Buttons)	6
5. Getting started	7
5-1. Measurement mode and parameter setting mode	7
5-2. Other functions	8
6. Battery replacement	9
7. Setting emissivity (reference)	10

1. Safety precautions

This instruction manual contains warnings and safety rules which must be observed by the user to ensure safe operation of the instrument and retain it in safe condition.

Therefore, read through these operating instructions before using the instrument.

1-1. DANGER

The connector for thermocouple is not insulated. Do not make measurement using a thermocouple when there is a risk of electrical shock hazard.

1-2. WARNING

KEW5515 is one of the portable laser applied instruments which are regulated by the consumer product safety law.

- Do not look directly into the laser.
- Do not point the laser directly at persons or animals.
- When measuring a reflective object such as mirrors, take extra caution so as not to look diffuse reflections.
- Keep out of reach of child or person who doesn't have the Product handling knowledge.
- Use the Product only as specified. Do not disassemble or modify the Product.

1-3. CAUTION

Please follow the precautions below for use to keep the instrument's functions proper and to enable accurate measurement.

- Do not contact this product with a measuring object.
This is a contactless thermometer. Contact with a hot section may cause un-repairable damages or inaccurate readings.
- Do not damage the measuring window (plastic lens).
Do not let a foreign object penetrate the measuring window, or drop a hard object on the measuring window.
- This instrument applies precise optical system. Do not give an excessive shock to the instrument.
- Do not bring the instrument closer to an electrostatic object.
- Emissivity of this instrument can be selected. When the emissivity setting is different from that of a measuring object, an inaccurate reading will occur.
- The sudden changes of the ambient temperature will cause inaccurate

readings. Wait a while to let the temperature of the instrument stabilize, and then measure.

- Remove the battery from the instrument, if the instrument is not in use for a long period or is put in storage.

1-4. Environmental precautions

- Do not use or store the instrument in a location where the instrument is exposed to direct sunlight, dust, lampblack and corrosive gas, or where the temperature and/ or humidity is high. Otherwise the measuring window gets soiled or deteriorated, which causes inaccurate readings.
- This instrument is not water-proof. Do not use in water or liquid nor make measurements or store where it may get wet.
- Keep the instrument away from an object which radiates a strong electromagnetic wave.

1-5. Maintenance

- Enclosure

Clean it with a soft cloth. To remove heavy stains, wipe it with a cloth wrung out with diluted neutral detergent.

Cautions:

Do not use chemical agents such as thinner, benzine or alcohol since these may cause a crack or fog on the surface of the measuring window, and consequently it may change the infrared radiation transmittance of the plastic lens.

1-6. Relation of distance and measuring diameter

The relation between the distance and measuring diameter is as follows.

However, the ratio between distance and measuring diameter varies depending on a distance. The more the distance increases, the larger area is needed.

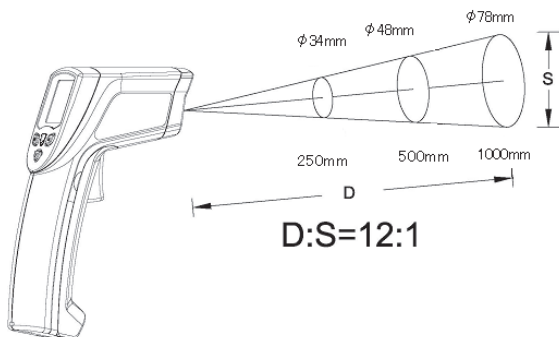

2. Features

This is a contactless handheld infrared thermometer.

Temperature measurement with a K-type thermocouple is also possible.

- Alarm function

The upper and lower temperature limits can be set. The red blinking backlight indicates that the measured value is below or over the pre-set limits.

- Auto-power-off function

To save battery life, the power is shut off automatically if no key is pressed for 6 seconds.

3. Specifications

Measuring range	-32 to 535°C
Accuracy	±3.0°C: -32 to -20 °C, ±2.0°C: -20 to +100°C, ±2%: 100 to 535°C
Infrared spectral band	5 to 14μm
Repeatability	Within ±1°C
Resolution	0.1°C
Response	500ms
Emissivity	Variable between 0.10 and 1.00 (by 0.01 steps): Before shipment: 0.95
Measuring diameter	1000mm/φ78mm (Distance/ Measuring dia.: 12:1)
Battery	One 9 V Dry cell battery (006P)
Operating temperature & humidity	0 to 50°C/ 10 to 90% RH

Auto power off	If no key is pressed for 6 seconds, the power is shut off automatically.
LCD display	LCD with backlight (blinks in red when alarm function is activated)
Collimation	Laser beam (630 to 670nm 1mW or less) specifies the center.
Display	Max/ Min/ Average value display
Dual display	Simultaneous display: Measured value and either of max, min, average or thermocouple value.
Thermocouple	K-type
Measuring range of thermocouple	-199 to 1372°C
Accuracy of thermocouple	$\pm(1.5\%+1^{\circ}\text{C})$: -40 to 1372°C
Dimension	180 × 130 × 40mm
Weight	Approx. 195g (excluding battery)
Accessories	Carrying case, One 9 V Dry cell battery (006P), Instruction manual
Approved standards	EN61326, IEC61000-4-2, IEC61000-4-3, IEC61000-4-8, IEC60825-1, CE Mark
Environmental standards	EU RoHS Directive compliant

4. Name of each part

4-1. Body

LASER RADIATION
DO NOT STARE INTO BEAM
CLASS 2 LASER PRODUCT

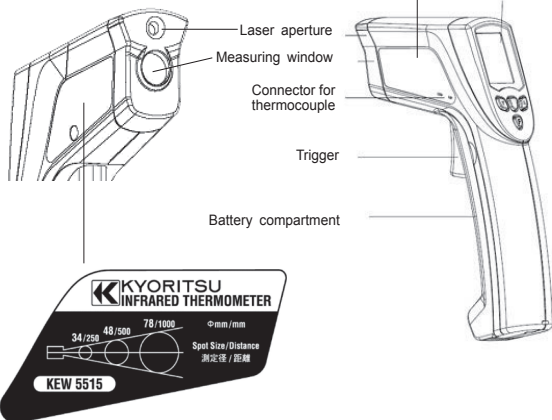

4-2. Display part (Buttons)

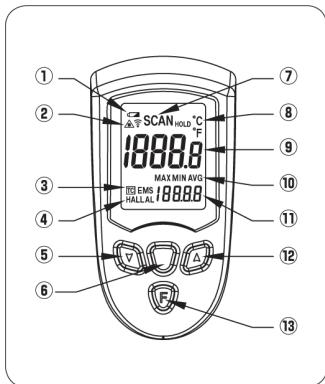

- ① Battery mark Appears to indicate low battery.
- ② Laser mark Appears when powering on the instrument.
Buzzer mark Appears when alarm function (P. 8) is enabled.
- ③ Thermocouple \square TC Lights up while measuring with K-type thermocou
Emissivity [EMS] Lights up while setting emissivity.
- ④ Upper limit alarm [HAL] Lights up while setting an upper limit for alarm.
Lower limit alarm [LAL] Lights up while setting a lower limit for alarm.
- ⑤ Cursor button (Down) Alters number.
- ⑥ Buzzer button Turns on/ off the buzzer sound.
- ⑦ SCAN Blinks during measurement.
HOLD Lights up while the display retains its last measurement (P. 8).
- ⑧ Unit Indicates measurement unit °C (P. 9).
- ⑨ Main display Shows measured values.
- ⑩ MAX/ MIN/ AVE Lights up when using each function (P. 7).
- ⑪ Sub display Shows the selected measurement mode and values in parameter setting mode (P. 7).
- ⑫ Cursor button (Up) Alters number.
- ⑬ Function button Switches between measurement and parameter setting modes (P. 7).

5. Getting started

5-1. Measurement mode and parameter setting mode

Pull the trigger on the instrument to take a measurement. Press the **F** button (Function button) to use other functions.

The main display shows measured values and the sub display shows values obtained with each function. The following flow chart shows the sequence and corresponding action.

Measurement mode

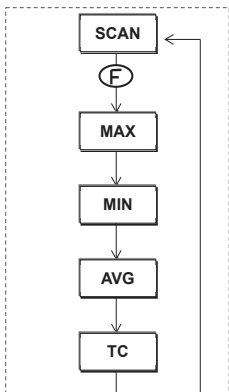

- **SCAN**: Shows measured values.
- **MAX**: Shows the maximum value taken during one measurement on the sub display.
- **MIN**: Shows the minimum value taken during one measurement on the sub display.
- **AVG**: Averages the values taken in one measurement and shows it on the sub display.
- **TC**: Shows measured values with using K-type thermocouple.

Parameter setting mode

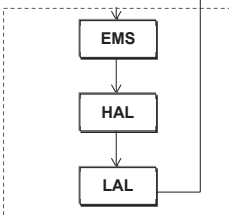

- **EMS**: Shows emissivity. (P. 10) Use the cursor buttons to alter emissivity.
- **HAL**: Shows the upper limit for alarm. (P. 8) Use the cursor buttons to alter the limit value. Red backlight blinks when a measured value exceeds this limit.
- **LAL**: Shows the lower limit for alarm. (P. 8) Use the cursor buttons to alter the limit value. Red backlight blinks when a measured value falls behind this limit.

* Auto power off function activates in 6 seconds. When the display becomes blank due to this power off function, pull the trigger.

5-2. Other functions

- **K-type thermocouple measurement**

Plug a K-type thermocouple into the connector for thermocouple, and press the function button to select **TC** function. Measured values using a thermocouple are displayed on the sub display.

- **Alarm function**

Red backlight blinks when a measured value exceeds or falls behind the values which are set on HAL and LAL functions. On both functions, it is possible to enable or disable the buzzer sound.

- **HOLD function**

The measured value is held and being displayed for 6 seconds after releasing the trigger.

- **Low battery warning** 

Battery mark appears when the battery voltage becomes low.

6. Battery replacement

When the battery is low, battery mark  appears on the display. Replace the battery with new one. When nothing is displayed on the display if attempted, it may also be battery exhaustion. Replace the battery with new one. Open the battery cover as below figure shows, and insert a new battery with correct polarity, and then close the cover.

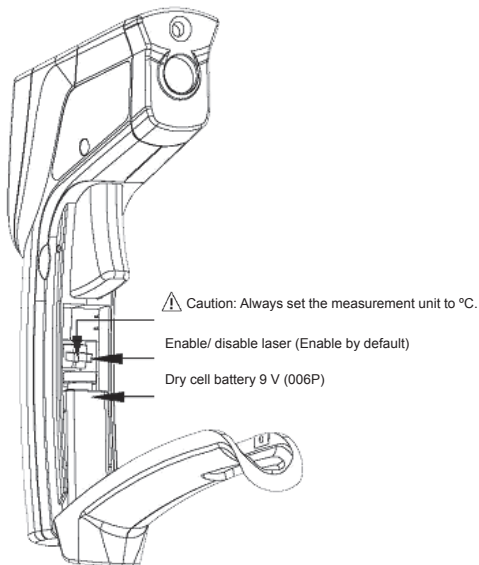

7. Setting emissivity (reference)

Quantity of infrared emitted radiation from objects depends on the objects' material, surface conditions, measuring temperatures and so on. The table below shows emissivity of some objects. Please note that these values are just for reference.

Please also refer to the estimated emissivity using a piece of commercially available black body tape.

Material	Emissivity	Material	Emissivity
Water, Ice	0.98	Cloth, Fabric (colored)	0.95
Soil	0.92 to 0.96	Leather, Fur	0.96
Concrete (wet)	0.96 to 0.98	Human skin	0.99
Concrete (dry)	0.91 to 0.95	Vegetable, Fruit	0.98
Ceramics	0.85 to 0.95	Dough	0.98
Stone, Asbestos	0.92	Meat	0.98
Plastics	0.90 to 0.95	Copper oxide	0.50 to 0.60
Rubber (black)	0.95	Ferric oxide	0.70 to 0.80
Wood	0.98	Painted surface	0.80
Paper	0.92	Tile	0.80

* Infrared thermometers can easily measure temperature from a distance with safe. They can be used for electrical or equipment maintenance, building control and process monitoring and other applications.

MEMO

DISTRIBUTOR

Kyoritsu reserves the rights to change specifications or designs described in this manual without notice and without obligations.



**KYORITSU ELECTRICAL
INSTRUMENTS
WORKS, LTD.**

2-5-20, Nakane, Meguro-ku,

Tokyo, 152-0031 Japan

Phone: +81-3-3723-0131

Fax: +81-3-3723-0152

Factory: Ehime, Japan

www.kew-ltd.co.jp