



AC/DC Clamp Sensor

KEW 8115

KYORITSU ELECTRICAL INSTRUMENTS WORKS, LTD.

1. Safety Warnings

This instrument has been designed, manufactured and tested according to IEC 61010: Safety requirements for Electronic Measuring apparatus, and delivered in the best condition after passing quality control tests. This instruction manual contains warnings and safety rules which have to be observed by the user to ensure safe operation of the instrument and to maintain it in safe condition. Therefore, read through these operating instructions before using the instrument.

⚠ WARNING

- Read through and understand instructions contained in this manual before using the instrument.
- Keep the manual at hand to enable quick reference whenever necessary.
- The instrument is to be used only in its intended applications.
- Understand and follow all the safety instructions contained in the manual.

It is essential that the above instructions are adhered to. Failure to follow the above instructions may cause injury and or instrument damage. Kyoritsu is by no means liable for any damage resulting from the instrument in contradiction to this cautionary note.

The symbol ⚠ indicated on the instrument, means that the user must refer to the related parts in the manual for safe operation of the instrument. It is essential to read the instructions wherever the symbol appears in the manual.

⚠ **DANGER** is reserved for conditions and actions that are likely to cause serious or fatal injury.

⚠ **WARNING** is reserved for conditions and actions that can cause serious or fatal injury.

⚠ **CAUTION** is reserved for conditions and actions that can cause minor injury or instrument damage.

⚠ DANGER

- Never make measurement on a circuit in which the electrical potential exceeds 300V in order to avoid possible shock hazard.
- Do not make measurement when thunder is rumbling. If the instrument is in use, stop the measurement immediately and remove the instrument from the measured object.
- Do not attempt to make measurement in the presence of flammable gasses. Otherwise, the use of the instrument may cause sparking, which can lead to an explosion.
- Put insulated protective gears when there is a danger of electrical shock hazard.
- The transformer jaws are made of metal and their tips are not completely insulated. Be especially careful about the possible shorting where the measured object has exposed metal parts.
- Never attempt to use the instrument if it's surface or your hand is wet.
- Otherwise, electrical shock accident may occur.
- Do not exceed the maximum allowable input of any measuring range.
- Never open the battery compartment cover and the instrument case when making a measurement.
- The instrument is to be used only in its intended applications or conditions. Otherwise, safety functions equipped with the instrument doesn't work, and instrument damage or serious personal injury may be caused.

⚠ WARNING

- Never attempt to make any measurement, if any abnormal conditions are noted, such as broken case, and exposed metal parts.
- Do not install substitute parts or make any modification to the instrument. Return the instrument to your local Kyoritsu distributor for repair or re-calibration in case of suspected faulty operation.
- Always keep your fingers and hands behind the barrier on the instrument to avoid the possible shock hazard.
- Do not try to replace batteries if the surface of the instrument is wet.
- Power off the instrument before opening the Battery Compartment Cover for a battery replacement.

⚠ CAUTION

- Do not step on or pinch the cord to prevent the jacket of cord from being damaged.
- The output connector shall be removed or connected without clamping a conductor. Otherwise, it may cause a failure.
- Do not expose the instrument to direct sunlight, high temperatures, humidity or dew.
- Do not use this instrument in dusty place and where the instrument is likely to get wet.
- Power off the instrument after use. Remove the batteries if the instrument is to be stored and will not be in use for a long period.
- Never give shocks, such as vibration or drop, which may damage the instrument.
- Use a damp cloth and detergent for cleaning the instrument. Do not use abrasives or solvents.
- Take sufficient care to avoid shock, vibration or excessive force when handling the instrument. Otherwise, precisely adjusted transformer jaws will be damaged.
- When transformer jaws do not fully close, never try to close them by force, but make them free to move and try again. If a foreign substance is stuck in the jaw tips, remove it.
- Do not open the jaws by force when transformer jaws are frozen.
- Hold the inserting part (except for the cord) and disconnect the Output Connector from the measuring instrument so as not to cause a break in the cable.

DISTRIBUTOR

2. Features

- Clamp sensor for AC/DC current measurements
- Designed to meet the international safety standard IEC61010-2-032 CAT III 300V, Pollution degree 2

3. Instrument layout

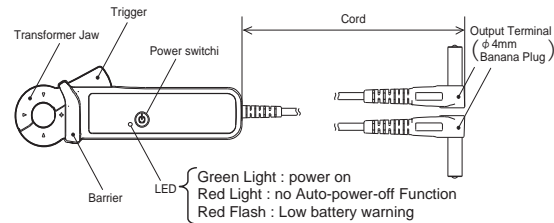

<Power on/ off>
One press of the Power Switch powers on the instrument and the green LED lights up. Another press of the Power Switch powers off the instrument. The instrument is automatically powered off in about 20 min after the last switch operation. (Auto-power-off Function)

<To disable the Auto-power-off Function>
Keep the Power Switch pressed down at least 3 sec and power on the instrument. Then the red LED lights up and the Auto-power-off Function doesn't activate when 20 min pass after the last switch operation.

4. Specification

Model	KEW8115	
Measuring Range	AC0.1 ~ 130Arms (185Apeak)	DC0 ~ 180A
Output voltage	AC/DC 10mV/A	
Accuracy (Input: sine wave) (*1)	50/60Hz: ±(1.2%rdg+0.4mV) 40 ~ 1kHz: ±(2.5%rdg+0.4mV)	±(1.2%rdg+0.4mV) (*2)
Temperature & humidity range (Guaranteed accuracy)	23±5°C, relative humidity 85% or less (no condensation)	
Operating temperature & humidity range	-10 ~ 55 °C, relative humidity 85% or less (no condensation)	
Storage temperature & humidity range	-30 ~ 70 °C, relative humidity 85% or less (no condensation) (*3)	
Temperature coefficient	(Accuracy at 23±5°C×±0.1%rdg)/°C should be added. (Temperature ranges: -10 to 18°C and 28 to 55°C)	
Output impedance	Approx 10Ω or less	
Location for use	Altitude 2000m or less, indoor use	
Applicable standards	IEC 61010-1 CAT III 300V, Pollution degree 2 IEC 61010-2-032 IEC 61326-1(EMC)	
Environmental standards	EU RoHS directive compliant AC3470V (RMS 50/60Hz) for 5 sec between Jaw and enclosure between enclosure and output terminal between Jaw and output terminal	
Withstand voltage	10MΩ or more/1000V between Jaw and enclosure between enclosure and output terminal between Jaw and output terminal	
Insulation resistance	10MΩ or more/1000V between enclosure and output terminal between Jaw and output terminal	
Power source	DC3V (size AAA alkaline battery LR03×2pcs)	
Auto-power-off	Approx 20 min after powering on the instrument	
Low battery warning	2.2±0.2V or less(*4) red LED flash	
Current consumption	25mA or less (battery voltage 3V)	
Continuous use	Approx 40 hours	
Conductor size	Max φ12mm	
Cord length	Approx 120cm	
Dimension	127(L)×42(W)×22(D)mm	
Weight	Approx 140g	
Accessories	Instruction manual, battery, Soft case	

- (*1) Under the EMC environment, the instrument temporarily reads errors due to the influences of electrical magnetic fields (about 15mV at 3V/m). Declared accuracy is guaranteed when a conductor under test is at the center of the Transformer jaws.
- (*2) This instrument doesn't have Zero Adjustment Function. This accuracy is defined after a zero-adjustment by using the device connected with this instrument. It is advisable to do Zero adjustment before making measurements because zero value may vary due to temperature change.
- (*3) without batteries
- (*4) powers off automatically at 1.9±0.2V or less
Instrument works properly even while Low battery indicator is flashing.

5. Measurement

- (1) Press the Power Switch to power on the instrument. The green LED lights up. (*5)
- (2) Connect the output terminal to the input terminal of the measuring instrument.
- (3) Press the trigger to open the transformer jaws, and clamp onto a conductor.
- (4) Confirm that the tips of the transformer jaws are surely closed.
- (5) Start a measurement. The measured conductor should be at the center of the jaws. (*6)
- (6) The measured result is displayed on the connected measuring instrument.

(*5) Keep the Power Switch pressed down at least 3 sec and power on the instrument to disable the Auto-power-off Function. In this case, the red LED lights up after powering on the instrument.

(*6) Triangle marks on the Transformer Jaws showing the center of the Jaws.

* Currents flowing from the top side (side with the Power switch) to the bottom side (Battery Compartment Cover) are positive, the ones flowing from the bottom side to the top side is negative.

* Max conductor size for KEW8115 is max φ12mm. Accurate measurements cannot be taken on conductors thicker than above size since the transformer jaws don't fully close.

* Do not give big shocks, when opening / closing transformer jaws.

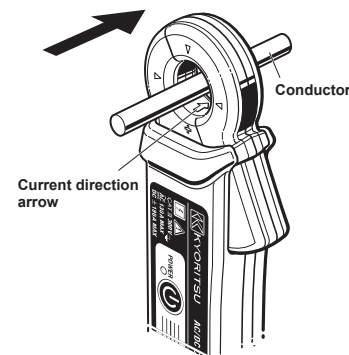

Safety Symbols

⚠	Refer to the instructions in the manual.
☐	Indicates instrument with double or reinforced insulation.
⚡	Indicates that this instrument can clamp on live bare conductors when the voltage to be tested is below Circuit - Ground-to-Earth voltage against the indicated Measurement Category.
~	AC
≡	DC
♻	This instrument satisfies the marking requirement defined in the WEEE Directive. This symbol indicates separate collection for electrical and electronic equipment.

○ Measurement Category

To ensure safe operation of measuring instruments, IEC 61010 establishes safety standards for various electrical environments, categorized as O to CAT IV, and called measurement categories. Higher-numbered categories correspond to electrical environments with greater momentary energy, so a measuring instrument designed for CAT III environments can endure greater momentary energy than one designed for CAT II.

O : Circuits which are not directly connected to the mains power supply.

CAT II : Electrical circuits of equipment connected to an AC electrical outlet by a power cord.

CAT III : Primary electrical circuits of the equipment connected directly to the distribution panel, and feeders from the distribution panel to outlets.

CAT IV : The circuit from the service drop to the service entrance, and to the power meter and primary overcurrent protection device (distribution panel).

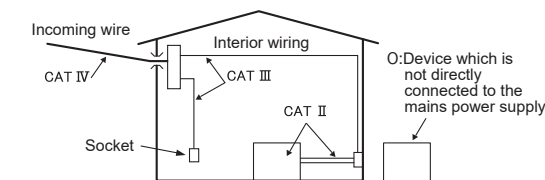

6. Battery Replacement

Replace the batteries when a low batter indicator (red LED) flashes on the LCD.

- (1) Press the Power Switch and power off the instrument.
- (2) Loosen 1 screw at the bottom side of the instrument to remove the Battery Compartment Cover.
- (3) Replace the batteries with new ones. (size AAA alkaline battery : LR03×2 pcs)
- (4) Install the Battery Compartment Cover and tighten the screws.

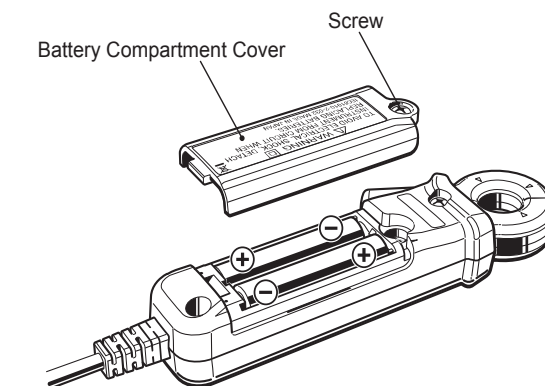

⚠ **WARNING**
• Do not try to replace batteries when making a measurement to avoid electric shock hazard.

⚠ **CAUTION**
• Do not mix batteries of different types or new batteries with used ones.
• Make sure to install batteries in correct polarity as indicated in the battery compartment.



KYORITSU ELECTRICAL INSTRUMENTS WORKS, LTD.

2-5-20, Nakane, Meguro-ku, Tokyo, 152-0031 Japan
Phone: +81-3-3723-0131
Fax: +81-3-3723-0152
Factory: Ehime, Japan

www.kew-ltd.co.jp